



Analysis: U.S. Patent 7,111,078

System and method for anonymous observation
and use of premium content by indirect access

Licensing or Purchasing Contacts:

Steve Hirst, shirst@maat.net, Principal
Alan Zeiger, zeiger@blankrome.com, Legal

Inventors:

Steven Hirst...Primary Contact
 President, MA'AT, Inc.
 2406 New Market Square South
 Bensalem, PA 19020
 215-313-5360
 shirst@maat.net
 www.maat.net

Gary S. Keorkunian
 President, GARA Systems, Inc.
 721 Dresher Rd. - Suite 2400
 Horsham, Pa. 19044
 215-449-1100
 gsk@gara.com
 www.gara.com

Assignee:

MA'AT, Inc.
 2406 New Market Square South
 Bensalem, PA 19020

GARA Systems, Inc
 721 Dresher Rd. - Suite 2400
 Horsham, Pa. 19044

Legal:

Alan L. Zeiger...Decision Maker
 Blank Rome Comisky & McCauley LLP
 Partner, Practice Group Chair, Privately
 Held and Emerging Companies.
 One Logan Square
 Philadelphia, PA 19103-6993
 215-569-5754
 zeiger@blankrome.com
 www.blankrome.com

MICHAEL C. GREENBAUM JR ... Patent
 Author
 Blank Rome Comisky & McCauley LLP
 Partner, Intellectual Property, IP Litigation
 600 New Hampshire Ave., NW
 Washington, DC 20037
 greenbaum@blankrome.com
 www.blankrome.com

Date Issued:	September 19, 2006
Application:	09/753,714
Filed:	January 4, 2001
Inventors:	Keorkunian; Gary S. (North Wales, PA) Hirst; Steven B. (Bensalem, PA) Waldron; Melodie (Bensalem, PA)
Assignee:	MA'AT Inc. / GARA, Inc.
Primary Examiner:	Kang; Paul H.
Primary Examiner:	
Attorney Or Agent:	Blank Rome LLP
U.S. Class:	709/246; 709/225; 709/239; 715/540
Field Of Search:	709/219; 709/229; 709/225; 709/239; 709/246; 705/78; 715/540; 715/530
International Class:	G06F 15/16; G06F 15/173; G06F 17/21
U.S Patent Documents:	5550984; 5673322; 5729537; 5742762; 5768391; 5774869; 5806043; 5812769; 5819285; 5889952; 5961593; 5996011; 6092198; 6173311; 6529886; 6539381; 2002/0004900; 2003/0191846
Foreign Patent Documents:	99/09725

Executive Summary

With the growing awareness and concern regarding privacy of consumer information, the ability to keep consumer information private is of monumental importance today.¹ Consumers and businesses are routinely shredding paper documents (including junk mail), declining purchase decisions “on-line” when private information is requested and purchasing all kinds of “protections” for their electronic devices to keep their information private.

Issued September 19, 2006, Patent Number 7,111,078 (MA`AT / GARA) defines and delineates anonymous transactions by indirect access. The indirect access can include but is not limited to:

- The Internet;
- Mobile devices;
- Telephone, etc.

The importance of the privacy of consumer and business information is further supported by recognizing the authors of the pending duplicative patent applications – Google, IBM, American Express, to name very few. The Key Aspects of the MA`AT / GARA patent are:

- Buyers shopping is anonymous to the seller(s);
- Buyers purchases are anonymous to the seller;
- Seller receives payments from the server with no knowledge of the buyer;
- Buyers purchases are presented on bills as server - no recognition of the seller; and,
- Buyers are at no risk for cookies, viruses, worms, etc.

The search feature of the US Patent and Trademark Office database² identified pending applications with claims of “anonymous, internet, purchase, privacy”. To determine the present and future value of the MA`AT / GARA patent, a sampling of the pending applications was analyzed. This analysis includes the application owner, application name, application number, application filing date, abstract and key aspects in comparison with the MA`AT / GARA patent.

¹ <http://www.internetnews.com/breakingnews/article.php/3740356>

² <http://uspto.gov>

Although a variety of terms are used (i.e. micro-payment, node, topology, etc.), analysis of the pending applications indicates repetition and duplication of the MA`AT / GARA patent. Given the fact that the MA`AT / GARA patent is final, the true value of future licensing terms to the authors of pending applications, the legal implications of patent infringement and the volume of duplicate patent applications is immeasurable.

The current and future value of the MA`AT / GARA patent are presented to include Net Present Value for licensing terms for the next five (5) years and presentation of the value of patent infringement for actual, current MA`AT / GARA willful patent violations.

This patent is offered for sale to interested parties by MA`AT / GARA.

Table of Contents

Executive Summary.....	Page <i>i</i>
Abstract and Exemplary Claim.....	Section A
Patent Analysis.....	Section B
Current Patent Infringements.....	Section C
Patent Comparisons.....	Section D
Potential Licensees.....	Section E

Attachments:

Patent Comparisons - Summary Table.....	Attachment D
U.S. Patent # 7,111,078.....	Attachment F
U.S. Patent #7,111,078 Diagrams.....	Attachment G
Assignment Change.....	Attachment H

Section A - Abstract³

A method and system to allow anonymous observation of premium content. A purchaser (user) of premium content connects and logs in to the server system via the Internet or other electronic medium. The server presents the user with a number of options for viewing or otherwise observing premium content (i.e. HTML Document, Video or Audio Stream, etc.) from a variety of providers. Through these options the user submits a request for an item of content to the server. The server then retrieves the content from the content provider's system or from a local cached version. If the content contains links (i.e. HTML Links) to other items of content at the provider, the server changes these links into links that request the same content from the server. The content is then delivered to the user's observation device (i.e. Web Browser, Telephone, etc.). The user is totally unknown to the provider — only known to the server.

Exemplary Claim

The server system completes access between the user and the provider with complete privacy for the user by maintaining separate connections for the user and the provider. The server system reformats any and all links to the user to maintain the user's total privacy and confidentiality. Purchases and payments can be made by the user through the server system to the provider with no sharing of the user information with the provider. The system applies to all digital access and retrieval technologies.

³ United States Patent 7,111,078

Section B - Patent Analysis

The MA`AT / GARA patent describes a server system for providing users with the ability to anonymously access, browse and purchase web based and other digital content. The patented technology accomplishes this by using two distinct methods, both identified as patent claims.

The first is the ability to deliver the content anonymously using a server system and content link reformatting model. Users request content via an indirect portal that implements the patented technology. The indirect portal retrieves the content from the provider's server and examines it for any links that may lead to additional content. If such links exist, the indirect portal modifies them so they become requests for the additional content via the indirect portal. The reformatted page or content is then delivered to the user. This allows the user to browse and surf the content the way they normally would. However, because they never make a request directly to the provider's server, their identity, including simple things like their IP address, cannot be discovered by the content provider.

To enhance the performance of this model, the patent design includes the ability to implement a cache that stores copies of the original provider's content. This technology accomplishes a similar result to surfing the web using traditional proxies; however, it takes an approach that does not require any existing proxy technology and, therefore, this patent also covers an alternative to the model used by most proxy servers.

The second and most important aspect of this patent provides users with the ability to pay for and receive "premium" content without revealing their identity to the content provider. This is accomplished through an accounting model that separates user payments from the charges imposed by content providers. The indirect portal service that implements the patented technology essentially positions itself in the middle of the transactions by collecting payment from the users that purchase premium content and paying providers that supply the content. The indirect portal, therefore, acts as a content and payment broker and aggregator between the buyers and sellers. Buyers can make payments to the

indirect portal using traditional methods such as credit cards — revealing their identity only to the indirect portal service — or using anonymous methods of payment such as stored value cards — revealing their identity to no one.

In recent years we have seen significant growth in the market for online digital content including music, e-books, software, movies, game rentals and more. Nevertheless the full potential of this growth has been inhibited by concerns over privacy, fraud and identity theft. Internet users — and mobile phone users — want to purchase more online, but are afraid to provide their personal and financial information to an ever growing list of online purveyors.

The ability to use a single payment provider for all of these purchases is a growing trend evidenced by services like PayPal, Google Checkout, Amazon WebStore and Fulfillment services and more. These services protect financial data and keep the buyer's financial data anonymous to the seller.

Section C - Current Patent Infringements

As seen in the patent applications filed by companies like Google, American Express, IBM, Intel and others, there is a tremendous interest and opportunity in this aspect of e-commerce. Furthermore, iTunes⁴ - the online media store from Apple - allows users to purchase and download music, movies, television shows and more using a single payment account. The content - provided by the producers of the material - is delivered to users without any direct connection to the content providers' (e.g. musicians, movie and TV producers, etc.) servers. The providers are paid by iTunes and receive no information about the consumers who actually made the purchase. This provision of content to the buyer without any direct connection to the provider is in direct infringement of the MA`AT / GARA patent. The consumer must reveal private information to iTunes in order make these purchases. Teenage angst is at its highest when the teen wants to purchase from iTunes and the parent does not allow the purchase due to privacy concerns with credit card information. The MA`AT / GARA patent technology would relieve parental concerns and keep all information private from iTunes.

Another example is the new service by Amazon that will allow users to download digital books⁵ - published by others - directly from Amazon's servers. Google is offering a similar service. Again, the purchaser must reveal private information to Amazon or Google in order to participate while Amazon and Google keep the purchaser's information anonymous to the original seller and reformat the original seller's product for digital use. This provision of content to the buyer without any direct connection to the provider is in direct infringement of the MA`AT / GARA patent.

The MA`AT / GARA patent includes the technology to allow purchasers access to these services without revealing their private information. As

purchasers (consumers and businesses) insist on complete anonymity in the digital marketplace, the purchaser of this patent will access significant licensing fees from all of these e-commerce programs.

For a better picture of the MA`AT / GARA patent, the following example describes the five (5) key aspects to the MA`AT / GARA patent:

1. A server for establishing a first connection to the buyer and a second connection to the seller to access the content.
 - a. Example: Buyer shops to purchase music and movies on-line. The buyer connects to a server without a direct connection to the seller using an indirect portal. The buyer remains anonymous to the seller.
2. A database for maintaining accounting information for the buyer and the seller.
 - a. Example: Buyer sets up an account with the indirect portal and the indirect portal maintains a database of information for payment to the seller. The buyer remains anonymous to the seller.
3. The server communicates with the seller over a separate connection to retrieve the content to be accessed by the user without disclosing identifying information about the buyer to the seller.
 - a. Example: Buyer's music and movies selection(s) are provided to the buyer by the indirect portal - not the seller. The buyer remains anonymous to the seller.
4. Wherein the content purchased by the buyer comprises a link to additional seller(s), the server delivers the content to the user while reformatting the link to prevent the user from following the link to the further content.
 - a. Example: While shopping for music and movies, the buyer sees other descriptions of music & movies of interest in the original site, selecting these links will still keep the buyer anonymous and only known to the indirect portal because the indirect portal has reformatted the link. The buyer remains anonymous to the seller.

⁴ <http://www.apple.com/itunes/>

⁵ http://www.businessweek.com/magazine/content/06_09/b3973111.htm

Section C - Current Patent Infringements *con't*

5. Wherein the server reformats the link to the further content by replacing the link to the further content with a modified link for accessing the further content through the server.
 - a. Example: The buyer makes purchases of music & movies through the link identified previously. The buyer remains anonymous to the seller.

The following table illustrates the current willful patent violations by FlashPay, NetCash, Apple iTunes and Amazon books according to the key aspects of the MA`AT / GARA patent. Additional samples are available but their inclusion would make this analysis onerous. It is important to note that of the current violators, only Amazon books has begun to expand to allow anonymous purchase of items through the Amazon portal to other providers (Target, Toys R Us, etc.). This expansion is not only expected but inevitable as consumer requests for anonymity continue to expand.

Key Aspects of MA`AT / GARA Patent	FlashPay	NetCash	Apple iTunes	Amazon Books
1. A server for establishing a first connection to the buyer and a second connection to the seller to access the content.	N/A	Maintains "separate databases to protect your privacy" (see attached)	Buyer connects to Apple iTunes – not to the provider of the music	Buyer connects to Amazon – not to the provider of the book (publisher)
2. A database for maintaining accounting information for the buyer and the seller.	Maintains database of buyers & sellers	Maintains "separate databases to protect your privacy" (see attached)	Maintains database of buyers & sellers – sends confirmation email of purchase to buyer	Maintains database of buyers & sellers – sends confirmation email of purchase to buyer
3. The server communicates with the seller over a separate connection to retrieve the content to be accessed by the user without disclosing identifying information about the buyer to the seller.	N/A	Maintains "separate databases to protect your privacy" (see attached)	Apple iTunes maintains cache of music from provider	Amazon maintains cache of digital books from provider/publisher
4. Wherein the content purchased by the buyer comprises a link to additional seller(s), the server delivers the content to the user while reformatting the link to prevent the user from following the link to the further content.	N/A	N/A	N/A	Amazon links buyer to another server (Target) while buyer is shopping at Amazon.
5. Wherein the server reformats the link to the further content by replacing the link to the further content with a modified link for accessing the further content through the server.	N/A	N/A	N/A	N/A

Section C - Current Patent Infringements *con't*



Value of Patent Infringements

Recent awards of \$6,000,000 and \$6,500,000 due to similar patent infringements are presented in the table below allotting these same awards in accordance with the number of direct patent infringements of the MA` AT / GARA Patent.

Estimate of Patent Infringement	
Flash Pay	\$ 6,000,000
Net Cash (Money Gram International, Inc.)	12,000,000
Apple iTunes	18,000,000
Amazon Digital Books	21,000,000
Expense per Infringement (30%)	<u>-17,100,000</u>
Net	\$39,900,000

Notes:

Recent awards of 6 million & 6.5 million for similar patent violations. See Ariba & Cisco:

Ariba: <http://www.law360.com/articles/74877>

Cisco: <http://www.law360.com/images/headings/logo.gif>

Section D - Patent Comparisons

The search feature of the US Patent and Trademark Office database⁶ identified pending applications with claims of “anonymous, internet, purchase, privacy”. To determine the present and future value of the MA`AT / GARA patent, a sampling of the pending applications was analyzed. This analysis includes the application owner, application name, application number, application filing date, abstract and key aspects in comparison with the MA`AT / GARA patent.

1. GOOGLE

Application	Abstract	Comparison
<p>20060080238 Application Filed: November 24, 2004 Name: Micro-payment System Architecture</p>	<p>A micro-payment system has buyers, sellers, and a broker. The buyers establish accounts with the broker and provide payment information allowing the broker to invoice the buyers. The sellers establish accounts with the brokers and specify terms for accessing items, including electronic content, available from the sellers. The sellers also provide payment information that allows the broker to credit the sellers for sales of the items. The broker aggregates the buyers' micro-payment purchases and invoices the buyers. The broker also aggregates the sellers' micro-payment sales and credits the sellers.</p>	<p>Repetition of MA`AT / GARA patent using “micro-payment” term with requirement of both buyer and seller setting up account with broker – direct duplication.. MA`AT / GARA patent has no such requirement.</p>

2. IBM

Application	Abstract	Comparison
<p>20030028470 Application Filed: July 26,2001 Name: Method for providing anonymous on-line transactions</p>	<p>A system and method for providing anonymous on-line transactions through a networked aggregate exchange server are provided. A request may be received at a certificate authority for an enhanced certificate. The certificate authority may determine whether the request qualifies for a certificate. The certificate authority may issue the certificate to a requester, if the request qualifies. An aggregate exchange server may receive an offer from a supplier with a certificate. The exchange server may receive a bid from a purchaser with a certificate. The exchange server may determine whether the purchaser bid and the supplier offer match. The exchange server may send the supplier the purchaser's enhanced certificate and may send the purchaser the supplier's enhanced certificate, if a match exists. The exchange server may receive agreement of the supplier and purchaser. Subsequently, the aggregate exchange server may anonymously execute the transaction.</p>	<p>Repetition of MA`AT / GARA patent using aggregate exchange server, issuance of “certificate” & “may” – direct duplication. The MA`AT / GARA patent completes the anonymous transactions without any qualifiers (i.e. certificate, may).</p>

3. AMERICAN EXPRESS

Application	Abstract	Comparison
<p>20070179866 Application Filed: April 10, 2007 Name: Method For Anonymous Purchase Of Goods Via An Ecommerce Website</p>	<p>A method and system for facilitating the purchase of goods and services anonymously from an e-commerce website is provided. The method includes providing a plurality of transaction account numbers, each of which is associated with a monetary load value. The transaction account numbers are stored in a database having a plurality of records. Each of the records corresponds to one of the transaction account numbers. None of the records are configured to store identifying information of a purchaser of one of the transaction numbers. A request for an authorization of a purchase transaction having a purchase value is received from a remote computer terminal. The request is associated with a transaction account number. If the purchase value does not exceed the monetary value associated with the transaction account number, an authorization message is sent to the remote computer terminal granting the request.</p>	<p>Repetition of MA`AT / GARA patent using transaction account number – direct duplication. Requires buyers to set up transaction accounts that are then used to authorize purchases if transaction account is sufficient. MA`AT / GARA has no such requirement.</p>

4. AMERICAN EXPRESS

Application	Abstract	Comparison
<p>20020019781 Application Filed: July 16, 2001 Name: Method and system for facilitating the anonymous purchase of goods and services from an e-commerce website</p>	<p>A method and system for facilitating the purchase of goods and services anonymously from an e-commerce website is provided. The method includes providing a plurality of transaction account numbers, each of which is associated with a monetary load value. The transaction account numbers are stored in a database having a plurality of records. Each of the records corresponds to one of the transaction account numbers. None of the records are configured to store identifying information of a purchaser of one of the transaction numbers. A request for an authorization of a purchase transaction having a purchase value is received from a remote computer terminal. The request is associated with a transaction account number. If the purchase value does not exceed the monetary value associated with the transaction account number, an authorization message is sent to the remote computer terminal granting the request.</p>	<p>Repetition of MA`AT / GARA patent using “transaction account number” – subsequent filing of previous American Express application: 20070179866. It is unclear why American Express is expanding their application.</p>

⁶ <http://uspto.gov>

Section D - Patent Comparisons

con't

5. HEWLETT-PACKARD COMPANY

Application	Abstract	Comparison
20030048906 Application Filed: May 10, 2002 Name: Anonymous transactions based on distributed processing	An entity that desires to engage in anonymous transactions first generates a transaction identification that does not uniquely identify the entity. Additionally, the entity splits an entity identification uniquely associated with the entity into a plurality of secret shares and thereafter sends the transaction identification and the plurality of secret shares to a plurality of shareholders. Subsequently, anonymous transactions on behalf of the entity may be directly conducted by the shareholders based in part upon the plurality of secret shares. In one embodiment of the present invention, the entity identification comprises a public key uniquely assigned to the entity.	Repetition of MA`AT / GARA patent using "entity identification & secret shares" does not provide a linkage between buyer & seller- direct duplication.. MA`AT / GARA patent technology maintains anonymity while linking buyer & seller.

6. HEWLETT-PACKARD COMPANY

Application	Abstract	Comparison
20030046202 Application Filed: April 12, 2002 Name: Anonymous transactions between an entity and a provider	An entity initiates a transaction with a provider by sending entity identification to a first anonymity service. In response, the entity receives a transaction identification, based on and uniquely associated with the entity identification, from the first anonymity service. Thereafter, the entity initiates acquisition of goods associated with the transaction by sending an acquisition request and the transaction identification to a second anonymity service. In this manner, enhanced security and privacy is achieved.	Repetition of MA`AT / GARA patent using "entity identification" and the addition of "acquisition of goods" - direct duplication.. Duplicates own Hewlett-Packard application 20030048906 with the addition of "acquisition of goods."

7. INTEL CORPORATION

Application	Abstract	Comparison
20070184830 Application Filed: April 17, 2007 Name: Anonymous Electronic Transactions	Techniques are disclosed for protecting privacy of parties to electronic transactions, such as transactions conducted through a GSM network. An anonymity service provider receives orders directed from its subscriber to a recipient for goods or services, along with information about its subscriber. The anonymity service provider relays the order to the recipient but withholds information about the subscriber, as the subscriber directs. The recipient receives payment for the good or service by way of a voucher from the anonymity service provider.	Repetition of MA`AT / GARA patent using anonymity service provider - direct duplication.

8. FIRST DATA CORPORATION

Application	Abstract	Comparison
20080052244 Application Filed: August 15, 2007 Name: Anonymous Transaction Authentication	An automated system for the confirmed efficient authentication of an anonymous subscriber's profile data. The system is comprised of software/hardware interface to facilitate centralized access and exchange to easily and inexpensively allow the confirmed authentication of subscriber profiles of customers wishing to blind their transactions, while maintaining current services. In one aspect the system allows a subscriber to anonymously accomplish credit card transactions without associating any aspect of the transaction with any information associated with the true identity of the subscriber.	Repetition of MA`AT / GARA patent using automated system & profiles - direct duplication.

9. FIRST DATA CORPORATION

Application	Abstract	Comparison
20040260653 Application Filed: July 30, 2004 Name: Anonymous Transactions	An anonymous transaction by a first party is accommodated without revealing the real identity of the first party by utilizing an alias. The alias is transmitted by a second party to the transaction to a secure database for authentication. Data is retrieved from the database based on the transmitted alias and analyzed, and an indication of authorization is returned to the second party. The alias may be a name, an alphanumeric identifier, or the like. The first party may be a child under the age of majority, and the transaction may include the use of a credit, debit, or prepaid card.	Repetition of MA`AT / GARA patent using "alias" - direct duplication. Also includes dangerous use by children under the age of majority. It is unclear why First Data Corporation is duplicating their own patent applications.

10. FIRST DATA CORPORATION

Application	Abstract	Comparison
20040254894 Application Filed: July 30, 2004 Name: Anonymous Transaction Authentication	An automated system for the confirmed efficient authentication of an anonymous subscriber's profile data. The system is comprised of software/hardware interface to facilitate centralized access and exchange to easily and inexpensively allow the confirmed authentication of subscriber profiles of customers wishing to blind their transactions, while maintaining current services. In one aspect the system allows a subscriber to anonymously accomplish credit card transactions without associating any aspect of the transaction with any information associated with the true identity of the subscriber.	Repetition of MA`AT / GARA patent using software/ hardware interface - direct duplication. It is unclear why First Data Corporation is duplicating their own patent applications.

Section D - Patent Comparisons

con't

11. SBC LABORATORIES, INC.

Application	Abstract	Comparison
<p>20030204445 Application Filed: April 26, 2002 Name: System And Method For Supporting Anonymous Transactions</p>	<p>A method for supporting anonymous transactions includes storing a first profile comprising first information associated with a first client. The first information includes identifying data and non-identifying data associated with the first client. The method also includes storing a second profile including second information associated with the first client. The second information includes at least a portion of the non-identifying data from the first profile. The method further includes receiving a request from the first client to engage in an anonymous transaction. The anonymous transaction is associated with a product. In addition, the method includes communicating an order for the product to one of the clients and facilitating completion of the order using the first profile. The second client can gain at least partial access to the second profile but not to the first profile associated with the first client.</p>	<p>Repetition of MA'AT / GARA patent using "profile" – direct duplication.</p>

12. MOTOROLA, INC.

Application	Abstract	Comparison
<p>20080056136 Application Filed: September 6, 2006 Name: Method And Apparatus For Performing Anonymous Source Routing</p>	<p>During operation, each client device will be provided with a list of addresses for all nodes within a network. The addresses for all nodes will be unique to a particular client device such that {address(node 1), address(node 2), . . . address(node n)} for a first client does not equal {address(node 1), address(node 2), . . . address(node n)} for a second client. Each client's address for a particular node will preferably only be known by the client and a naming server. When sending a message to a destination node, a client device will create a source route consisting of the unique addresses. Because each client's address for a particular node will only be known to itself and the naming server, anyone who intercepts the route will not know what nodes along the route are used for routing the message.</p>	<p>Repetition of MA'AT / GARA patent using "nodes" for buyer, seller and server – direct duplication.</p>

13. FRANCE TELECOM

Application	Abstract	Comparison
<p>20080052227 Application Filed: May 17, 2005 Name: Anonymous and Secure Internet Payment Method and Mobile Devices</p>	<p>An anonymous and secure on-line payment system and method based on the partially blind signature cryptographic method with revocable anonymity. To this end, an Anonymity Server (SA) enables the Customer (C) to acquire on-line anonymous payment means on the basis of a protocol that does not enable the Anonymity Server to link the payment means to the Customer (C). The Payment Server (SdP) comprises means for opening an anonymous account using the anonymous payment means (50). A Customer (C) can make an on-line purchase from a Merchant Site (SM) without having to give a bank card number and remaining anonymous to the merchant and more generally to any entity present in the transaction or absent therefrom. However, this anonymity may be revoked by a trusted entity in the event of fraud on the Customer. Finally, a Customer can make payments when on the move.</p>	<p>Repetition of MA'AT / GARA patent using "anonymity server" – direct duplication. Includes a puzzling statement that privacy "can be revoked".</p>

14. MILDE & HOFFBERG

Application	Abstract	Comparison
<p>20040034544 Application Filed: April 24, 2003 Name: Completely anonymous purchasing of goods on a computer network</p>	<p>A system for anonymous purchase of goods involving a Carrier who delivers the goods to the Customer, comprising the steps of Customer requests a Vendor's Clickshare-protected URL representing the desire to purchase some physical goods, the Vendor validates the token, determines access rights, and if a purchase is involved, the cost of the content to be delivered, the Vendor checks various Confirmation and Credit Limit thresholds, asking the Customer to confirm the purchase price, if necessary, the Vendor asks the Customer to select a Carrier from the list of Carriers the Vendors uses, the Vendor asks CVS for a Token that represents the capability to ask a Carrier for a shipping identifier, the Vendor redirects the Customer's browser to the Carrier's server, sending the Customer's Token, the Vendor's Token, and a basic description of the packages, if available (number, weight, export restrictions), the Carrier Server validates the Vendor's Token and uses the Customer's Token to request information about the Customer, primarily their Site-Specific Customer Identifier (SCID), shipping address, and any additional shipping instructions stored on the Customer's Billing Agent.</p>	<p>Repetition of MA'AT / GARA patent using "token" – direct duplication.</p>

Section D - Patent Comparisons

con't

15. VENABLE, CAMPILLO, LOGAN & MEANEY, P.C.

<i>Application</i>	<i>Abstract</i>	<i>Comparison</i>
20070226152 <i>Application Filed:</i> March 22, 2006 <i>Name:</i> System And Method For Anonymous Transactions And Conveyances	A system and associated methods enabling a customer or transferee to acquire a product or service from a merchant, vendor or transferor through the services of an intermediate entity using a transaction protocol that shields the customer's name or other identifying information from the intermediate entity, the merchant, vendor or transferor, the delivery agent, and other agencies that may be ancillary to the transaction. The system and method is also useful for allowing anonymous sales from a seller to a buyer and conveyances from a transferor to a transferee.	Repetition of MA`AT / GARA patent using intermediate entity – direct duplication.

Although a variety of terms are used (i.e. micro-payment, node, topology, etc.), analysis of the pending applications indicates repetition and duplication of the MA`AT / GARA patent. Given the fact that the MA`AT / GARA patent is final, the true value of future licensing terms to the authors of pending applications, the legal implications of patent infringement and the volume of duplicate patent applications is immeasurable.

Section E - Potential Licensees

Patent valuation is determined by multiple revenue sources. One such revenue source is the potential licensing opportunities for the MA`AT / GARA patent. The provision of anonymity for consumer and business purchases is crucial to the future e-commerce marketplace.⁷ Consumers live in constant fear of identity thieves and allow that fear to affect their purchase decisions, use of the internet and use of their credit cards. Although they do not understand the mechanisms, consumers are well aware that providers have access to their private information through their computers. In fact, the provider's access to private information may even be worse than feared.⁸

Any provider wanting to offer goods and services through a digital portal (Web browser, cell phone, etc.) will be a licensee for the MA`AT / GARA patent. The first licensee will see immediate appreciable gains by offering complete anonymity for purchases. Subsequent licensees will be consumer required to offer the anonymous methodology for purchases as consumers value

their privacy and decry the placement of "cookies" and such on their computers without their knowledge and permission.

A very small sampling of current e-commerce products includes:

- Apple: iTunes store⁹
- Google : Google Books and Video¹⁰
- Amazon: Amazon Pages¹¹
- Microsoft: Zune store¹²
- Visa: e-passport¹³
- NetCash: NetCash processes your transaction through the use of a random code¹⁴
- First Data: Contactless Payments¹⁵
- The Adult Entertainment Industry (IE: XTube.com)¹⁶

Valuation of the potential license fees is illustrated below. The table presents the number of licenses granted, at a per license fee of \$25,000 (based on Windows licensing fees for Digital Rights Management). The license fee is charged each year so growth is cumulative. Management expenses for licensing the product are projected at \$1,500 per license.

	Year 1	Year 2	Year 3	Year 4	Year 5
Licenses Granted	10	25	35	55	65
Licensing Fees (1)	250,000	625,000	875,000	1,375,000	1,625,000
Licensing Expenses (2)	(15,000)	(37,500)	(52,500)	(82,500)	(97,500)
Net	235,000	587,500	822,500	1,292,500	1,527,500
Annual Discount Rate	10%				
NPV	3,148,382				
<i>Notes:</i>					
(1) Estimate per license based on Windows licensing fees for Digital Rights Management	25,000				
(2) Estimate per license for management of licensing product	(1,500)				

⁷ http://www.firstmonday.org/issues/issue3_6/dyson/index.html

⁸ <http://epic.org/reports/surfer-beware3.html>

⁹ <http://www.apple.com/itunes/store/>

¹⁰ <http://books.google.com/>

¹¹ <http://www.npr.org/templates/story/story.php?storyId=4990112>

¹² <http://www.zune.net/en-US/>

¹³ <https://www.epassporte.com/>

¹⁴ <https://www.netcash.com/engine/overview/welcome>

¹⁵ http://www.firstdata.com/product_solutions/payment_solutions/rfid_contactless_payments.htm

¹⁶ <http://xtube.com/warning.php?ref=>

Patent Comparisons – Summary

Section D –Table

Owner	MA`AT / GARA	Google	IBM	American Express	American Express	Hewlett-Packard Company	Hewlett-Packard Company	Intel Corporation
Name	System and method for anonymous observation and use of premium content by indirect access	Micro-payment System Architecture	Method for providing anonymous on-line transactions	Method for anonymous purchase of goods via an ecommerce website	Method and system for facilitating the anonymous purchase of goods and services from an e-commerce website	Anonymous transactions based on distributed processing	Anonymous transactions between an entity and a provider	Anonymous electronic transactions
Patent Number	7,111,078	20060080238 Application	20030028470 Application	20070179866 Application	20020019781 Application	20030048906 Application	20030046202 Application	20070184830 Application
Date(s)	Filing date: Jan 4, 2001 Priority date: Jan 4, 2000 Issue date: Sep 19, 2006	Filed: November 24, 2004	Filed: July 26, 2001	Filed: April 10, 2007	Filed: July 16, 2001	Filed: May 10, 2002	Filed: April 12, 2002	Filed: April 17, 2007
Abstract	A method and system that allows anonymous observation of premium content. A purchaser (user) of premium content connects and logs in to the server system via the Internet or other electronic medium. The server presents the user with a number of options for viewing or otherwise observing premium content (i.e. HTML Document, Video or Audio Stream, etc.) from a variety of providers. Through these options the user submits a request for an item of content to the server. The server then retrieves the content from the content provider's system or from a local cached version. If the content contains links (i.e. HTML Links) to other items of content at the provider, the server changes these links into links that request the same content from the server. The content is then delivered to the user's observation device (i.e. Web Browser, Telephone, etc.).	A micro-payment system has buyers, sellers, and a broker. The buyers establish accounts with the broker and provide payment information allowing the broker to invoice the buyers. The sellers establish accounts with the brokers and specify terms for accessing items, including electronic content, available from the sellers. The sellers also provide payment information that allows the broker to credit the sellers for sales of the items. The broker aggregates the buyers' micro-payment purchases and invoices the buyers. The broker also aggregates the sellers' micro-payment sales and credits the sellers.	A system and method for providing anonymous on-line transactions through a networked aggregate exchange server are provided. A request may be received at a certificate authority for an enhanced certificate. The certificate authority may determine whether the request qualifies for a certificate. The certificate authority may issue the certificate to a requester, if the request qualifies. An aggregate exchange server may receive an offer from a supplier with a certificate. The exchange server may receive a bid from a purchaser with a certificate. The exchange server may determine whether the purchaser bid and the supplier offer match. The exchange server may send the supplier the purchaser's enhanced certificate and may send the purchaser the supplier's enhanced certificate, if a match exists. The exchange server may receive agreement of the supplier and purchaser. Subsequently, the aggregate exchange server may anonymously execute the transaction.	A method and system for facilitating the purchase of goods and services anonymously from an e-commerce website is provided. The method includes providing a plurality of transaction account numbers, each of which is associated with a monetary load value. The transaction account numbers are stored in a database having a plurality of records. Each of the records corresponds to one of the transaction account numbers. None of the records are configured to store identifying information of a purchaser of one of the transaction numbers. A request for an authorization of a purchase transaction having a purchase value is received from a remote computer terminal. The request is associated with a transaction account number. If the purchase value does not exceed the monetary value associated with the transaction account number, an authorization message is sent to the remote computer terminal granting the request.	A method and system for facilitating the purchase of goods and services anonymously from an e-commerce website is provided. The method includes providing a plurality of transaction account numbers, each of which is associated with a monetary load value. The transaction account numbers are stored in a database having a plurality of records. Each of the records corresponds to one of the transaction account numbers. None of the records are configured to store identifying information of a purchaser of one of the transaction numbers. A request for an authorization of a purchase transaction having a purchase value is received from a remote computer terminal. The request is associated with a transaction account number. If the purchase value does not exceed the monetary value associated with the transaction account number, an authorization message is sent to the remote computer terminal granting the request.	An entity that desires to engage in anonymous transactions first generates a transaction identification that does not uniquely identify the entity. Additionally, the entity splits an entity identification uniquely associated with the entity into a plurality of secret shares and thereafter sends the transaction identification and the plurality of secret shares to a plurality of shareholders. Subsequently, anonymous transactions on behalf of the entity may be directly conducted by the shareholders based in part upon the plurality of secret shares. In one embodiment of the present invention, the entity identification comprises a public key uniquely assigned to the entity.	An entity initiates a transaction with a provider by sending entity identification to a first anonymity service. In response, the entity receives transaction identification, based on and uniquely associated with the entity identification, from the first anonymity service. Thereafter, the entity initiates acquisition of goods associated with the transaction by sending an acquisition request and the transaction identification to a second anonymity service. In this manner, enhanced security and privacy is achieved.	Techniques are disclosed for protecting privacy of parties to electronic transactions, such as transactions conducted through a GSM network. An anonymity service provider receives orders directed from its subscriber to a recipient for goods or services, along with information about its subscriber. The anonymity service provider relays the order to the recipient but withholds information about the subscriber, as the subscriber directs. The recipient receives payment for the good or service by way of a voucher from the anonymity service provider.
Key Aspects	<ul style="list-style-type: none"> Buyers purchases are anonymous to the seller Seller receives payments from the server with no knowledge of the buyer Buyers purchases are presented on bills as server – no recognition of the seller Buyers are at no risk for cookies, viruses, worms, etc. 	<ul style="list-style-type: none"> Repetition of MA`AT / GARA patent using "micro-payment" term 	<ul style="list-style-type: none"> Repetition of MA`AT / GARA patent using aggregate exchange server, issuance of "certificate" & "may." 	<ul style="list-style-type: none"> Repetition of MA`AT / GARA patent using transaction account number 	<ul style="list-style-type: none"> Repetition of MA`AT / GARA patent using "transaction account number" 	<ul style="list-style-type: none"> Repetition of MA`AT / GARA patent using "entity identification & secret shares" does not provide a linkage between buyer & seller. 	<ul style="list-style-type: none"> Repetition of MA`AT / GARA patent using "entity identification" 	<ul style="list-style-type: none"> Repetition of MA`AT / GARA patent using anonymity service provider

Patent Comparisons – Summary *con't*

Section D –Table

Owner	First Data Corp.	First Data Corp.	First Data Corp.	SBC Labs, Inc	Motorola, Inc.	France Telecom	Milde & Hoffberg	Venable, Campillo, Logan & Meaney, P.C.
Name	Anonymous transaction authentication	Anonymous transactions	Anonymous transaction authentication	System and method for supporting anonymous transactions	Method and apparatus for performing anonymous source routing	Anonymous and secure internet payment method and mobile devices	Completely anonymous purchasing of goods on a computer network	System and method for anonymous transactions and conveyances
Patent Number	20080052244 Application	20040260653 Application	20040254894 Application	20030204445 Application	20080056136 Application	20080052227 Application	20040034544 Application	20070226152 Application
Date(s)	Filed: August 15, 2007	Filed: July 30, 2004	Filed: July 30, 2004	Filed: April 26, 2002	Filed: September 6, 2006	Filed: May 17, 2005 371 Date: October 29, 2007	Filed: April 24, 2003	Filed: March 22, 2006
Abstract	An automated system for the confirmed efficient authentication of an anonymous subscriber's profile data. The system is comprised of software/hardware interface to facilitate centralized access and exchange to easily and inexpensively allow the confirmed authentication of subscriber profiles of customers wishing to blind their transactions, while maintaining current services. In one aspect the system allows a subscriber to anonymously accomplish credit card transactions without associating any aspect of the transaction with any information associated with the true identity of the subscriber.	An anonymous transaction by a first party is accommodated without revealing the real identity of the first party by utilizing an alias. The alias is transmitted by a second party to the transaction to a secure database for authentication. Data is retrieved from the database based on the transmitted alias and analyzed, and an indication of authorization is returned to the second party. The alias may be a name, an alphanumeric identifier, or the like. The first party may be a child under the age of majority, and the transaction may include the use of a credit, debit, or prepaid card.	An automated system for the confirmed efficient authentication of an anonymous subscriber's profile data. The system is comprised of software/hardware interface to facilitate centralized access and exchange to easily and inexpensively allow the confirmed authentication of subscriber profiles of customers wishing to blind their transactions, while maintaining current services. In one aspect the system allows a subscriber to anonymously accomplish credit card transactions without associating any aspect of the transaction with any information associated with the true identity of the subscriber.	A method for supporting anonymous transactions includes storing a first profile comprising first information associated with a first client. The first information includes identifying data and non-identifying data associated with the first client. The method also includes storing a second profile including second information associated with the first client. The second information includes at least a portion of the non-identifying data from the first profile. The method further includes receiving a request from the first client to engage in an anonymous transaction. The anonymous transaction is associated with a product. In addition, the method includes communicating an order for the product to one of the clients and facilitating completion of the order using the first profile. The second client can gain at least partial access to the second profile but not to the first profile associated with the first client.	During operation, each client device will be provided with a list of addresses for all nodes within a network. The addresses for all nodes will be unique to a particular client device such that {address(node 1), address(node 2), . . . address(node n)} for a first client does not equal {address(node 1), address(node 2), . . . address(node n)} for a second client. Each client's address for a particular node will preferably only be known by the client and a naming server. When sending a message to a destination node, a client device will create a source route consisting of the unique addresses. Because each client's address for a particular node will only be known to itself and the naming server, anyone who intercepts the route will not know what nodes along the route are used for routing the message.	An anonymous and secure on-line payment system and method based on the partially blind signature cryptographic method with revocable anonymity. To this end, an Anonymity Server (SA) enables the Customer (C) to acquire on-line anonymous payment means on the basis of a protocol that does not enable the Anonymity Server to link the payment means to the Customer (C). The Payment Server (SdP) comprises means for opening an anonymous account using the anonymous payment means (50). A Customer (C) can make an on-line purchase from a Merchant Site (SM) without having to give a bank card number and remaining anonymous to the merchant and more generally to any entity present in the transaction or absent therefrom. However, this anonymity may be revoked by a trusted entity in the event of fraud on the Customer. Finally, a Customer can make payments when on the move.	A system for anonymous purchase of goods involving a Carrier who delivers the goods to the Customer, comprising the steps of Customer requests a Vendor's Clickshare-protected URL representing the desire to purchase some physical goods, the Vendor validates the token, determines access rights, and if a purchase is involved, the cost of the content to be delivered, the Vendor checks various Confirmation and Credit Limit thresholds, asking the Customer to confirm the purchase price, if necessary, the Vendor asks the Customer to select a Carrier from the list of Carriers the Vendor uses, the Vendor asks CVS for a Token that represents the capability to ask a Carrier for a shipping identifier, the Vendor redirects the Customer's browser to the Carrier's server, sending the Customer's Token, the Vendor's Token, and a basic description of the packages, if available (number, weight, export restrictions), the Carrier Server validates the Vendor's Token and uses the Customer's Token to request information about the Customer, primarily their Site-Specific Customer Identifier (SCID), shipping address, and any additional shipping instructions stored on the Customer's Billing Agent.	A system and associated methods enabling a customer or transferee to acquire a product or service from a merchant, vendor or transferor through the services of an intermediate entity using a transaction protocol that shields the customer's name or other identifying information from the intermediate entity, the merchant, vendor or transferor, the delivery agent, and other agencies that may be ancillary to the transaction. The system and method is also useful for allowing anonymous sales from a seller to a buyer and conveyances from a transferor to a transferee.
Key Aspects	• Repetition of MA`AT / GARA patent using automated system & profiles	• Also includes dangerous use by children under the age of majority.	• Repetition of MA`AT / GARA patent using software/ hardware interface	• Repetition of MA`AT / GARA patent using "profile"	• Repetition of MA`AT / GARA patent using "nodes" for buyer, seller and server	• Repetition of MA`AT / GARA patent using "anonymity server" – can be revoked	• Repetition of MA`AT / GARA patent using "token"	• Repetition of MA`AT / GARA patent using intermediate entity

Attachment F

United States Patent 7,111,078

System and method for anonymous observation and use of premium content by indirect access through portal

Date Issued:	September 19, 2006
Application:	09/753,714
Filed:	January 4, 2001
Inventors:	Keorkunian; Gary S. (North Wales, PA) Hirst; Steven B. (Bensalem, PA) Waldron; Melodie (Bensalem, PA)
Assignee:	Hirst; Steven B. (Bensalem, PA)
Primary Examiner:	Kang; Paul H.
Primary Examiner:	
Attorney Or Agent:	Blank Rome LLP
U.S. Class:	709/246; 709/225; 709/239; 715/540
Field Of Search:	709/219; 709/229; 709/225; 709/239; 709/246; 705/78; 715/540; 715/530
International Class:	G06F 15/16; G06F 15/173; G06F 17/21
U.S Patent Documents:	5550984; 5673322; 5729537; 5742762; 5768391; 5774869; 5806043; 5812769; 5819285; 5889952; 5961593; 5996011; 6092198; 6173311; 6529886; 6539381; 2002/0004900; 2003/0191846
Foreign Patent Documents:	99/09725

Abstract:	A method and system allow anonymous observation of premium content. A purchaser (user) of premium content connects and logs in to the server system via the Internet or other electronic medium. The server presents the user with a number of options for viewing or otherwise observing premium content (i.e. HTML Document, Video or Audio Stream, etc.) from a variety of providers. Through these options the user submits a request for an item of content to the server. The server then retrieves the content from the content provider's system or from a local cached version. If the content contains links (i.e. HTML Links) to other items of content at the provider, the server changes these links into links that request the same content from the server. The content is then delivered to the user's observation device (i.e. Web Browser, Telephone, etc.).
Claim:	<p>We claim:</p> <ol style="list-style-type: none"> 1. A system for allowing a user to access content from a provider, the system comprising: a server for establishing a first connection to the user and a second connection to the provider to access the content; and a database for maintaining accounting information for the user and for the provider; wherein the server communicates with the provider over the second connection to retrieve the content to be accessed by the user without disclosing identifying information about the user to the provider; wherein when the content comprises a link to further content, the server delivers the content to the user while reformatting the link to prevent the user from following the link to the further content, and wherein the server reformats the link to the further content by replacing the link to the further content with a modified link for accessing the further content through the server. 2. A system of claim 1, wherein the server retrieves the content from the provider and stores the content in a cache for delivery to the user. 3. A system of claim 1, wherein the server measures an amount of time the user spends viewing the content and enters the amount of time into the database. 4. A system of claim 1, wherein the server debits a fulfilled request from the user for the content from an account maintained for the user in the database without association to the provider or content requested. 5. A system of claim 4, wherein the fulfilled request is credited to an account maintained for the provider in the database without association to the user making the request.

Attachment F *con't*

United States Patent 7,111,078

System and method for anonymous observation and use of premium content by indirect access through portal

Claim:	<p>6. A system of claim 1, wherein the database comprises an account for the user in which the user can purchase rights to view the content without association to the specific content that will be viewed or otherwise observed.</p> <p>7. A system of claim 1, wherein the database stores a password which the user must provide before the user can access the content.</p> <p>8. A system of claim 7, wherein the database stores, in association with the password, a preset amount of time for which the user is permitted to access the content using the password.</p> <p>9. A system of claim 7, wherein the database stores, in association with the password, a preset amount of the content that the user is permitted to access using the password.</p> <p>10. A system of claim 7, wherein the database stores, in association with the password, only information preset independently of the user.</p>
Description:	<p>BACKGROUND OF THE INVENTION</p> <p>1. Technical Field</p> <p>The present invention pertains in general to computer software, and more particularly, to providing the components that give Internet based and other technology based providers the ability to charge fees for content, while allowing users to maintain their anonymity.</p> <p>2. Description of Related Art</p> <p>With the growth of the Internet, and particularly of the World-Wide Web, many companies have offered premium content over the Internet. To access such premium content, a user must typically enter a credit-card number, both for billing purposes and (when required) to establish proof of legal maturity.</p> <p>However, companies providing such premium content may wish to allow customers a free, time-limited preview of the content. In that case, there must be a way of ensuring that the person using the preview does so only during the specified time. A generic guest ID and password allow no such function. While the user can be prompted to enter a credit card, with the promise that the card will not be charged during the preview period, many users are understandably suspicious of such a promise.</p> <p>Also, a user may wish to remain anonymous during the preview period, or for that matter throughout the user's subscription to the premium service. That is especially the case with "adult" services. The user's anonymity can be breached in several ways. For example, when the user's computer forms a TCP/IP connection to the server, the user's computer sends certain identifying information to the server, which stores that information in an access log. Such information can be used to identify the user. Also, if another person (such as a family member or a co-worker) accesses the user's computer, that other person can easily identify the URL's of the last several Web sites that the user has accessed. Further, in the case of premium content, a charge will appear on the user's credit-card statements. Many users find such recording of their identities objectionable. On the other hand, companies providing premium content still have to be able to charge their customers.</p> <p>SUMMARY OF THE INVENTION</p> <p>It will thus be readily apparent that a need exists in the art to overcome the above problems. It is therefore an object of the invention to allow users to access premium content for a limited time. It is another object of the invention to allow users to access premium (or other) content on the Web while obscuring their identity to both the server and the Web browsers running on such users' computers.</p>

Attachment F *con't*

United States Patent 7,111,078

System and method for anonymous observation and use of premium content by indirect access through portal

<p>Description:</p>	<p>More specifically, the present invention has the following objects: 1. To provide Providers with an outlet for selling their Content to anonymous Users. 2. To provide Providers with the ability to promote their Content by giving free access to Content for a limited time. 3. To provide Users with the ability to purchase Content from a variety of Providers while remaining anonymous. 4. To provide Users with the ability to access that Content while remaining anonymous. To provide Portals with the ability to gather information about the Content being viewed so Providers can be paid accordingly</p> <p>To achieve the objects outlined above, as well as other objects, the present invention is directed to a method and system, usable with the World Wide Web and other communication technology, for anonymously delivering content to users, while giving the providers the ability to charge for the content, as well as for delivering such content to users free of charge for a limited time.</p> <p>The present invention disclosed and claimed herein, comprises a method and system for allowing users to purchase for the right to anonymously view or otherwise observe premium content or use premium services available from a variety of providers.</p> <p>The present invention would typically be implemented through portals, so that the users do not access the content directly. The portal provides a variety of providers with an outlet to sell content or services (hereafter called content) to an anonymous user base. The portal would charge customers (hereafter called users) for the right to view the content available from the providers. The portal will maintain the information about the content, however, not the specifics on the user who purchased it. This permits the users to maintain their anonymity, while allowing the portal to charge fees for the content. The fees can be waived during an initial preview period, if a provider so desires.</p> <p>Viewing as used herein refers to the ability to observe the content (i.e. look at web pages, read text, view still images or motion pictures, listen to audio, etc.). In addition, this system can apply to other observations such as tasting, smelling, and feeling if and when techniques capable of transmitting this content electronically are developed.</p> <p>Instead of users purchasing the content directly from the providers--where their anonymity would be compromised--users purchase content anonymously through the portal. The portal serves as an outlet for several providers. When users access the portal they are presented with links to content from a variety of providers. When users use that content, they are not physically visiting the provider's site, as this may compromise their anonymity. Instead, the portal using the method described herein retrieves the content, either from the provider's site directly or from a cached or local copy of the content, and transmits it to the user. In addition, the portal using the method described herein could establish a non-traceable link between the user and provider for the content to be transmitted. If the content delivered contains links to additional content, the system provides for the link to be reformatted before displaying the content to the user. As users view the content, their account with the portal is charged accordingly; however, the specific content that they are viewing is not tracked.</p> <p>As content is used, the provider's account is credited, again with no tracking of information about the specific user using the content. This provides the portal with the tracking method and system necessary to pay providers for the content that is viewed by the portal's users. Portals and providers can charge users using a "charge-for-item" method or a "charge-per-time" method. The former method would charge users a specified amount for using a specific item of content. The latter method would charge users a specified amount per minute for spending time with the content.</p> <p>In addition to purchasing content through the portal, users can acquire access via other means as well. The portal, possibly in conjunction with providers, can setup a number of predefined accounts with a preset limit of time or content usage allowed. The user can then purchase these accounts for cash or other means from retailers. The retailer would supply the user with the account number, password and time or content limit. This information can be supplied via a small card similar to long distance phone cards currently available. The providers may also use these cards to promote their services by giving away cards to prospective customers.</p>
----------------------------	--

Attachment F *con't*

United States Patent 7,111,078

System and method for anonymous observation and use of premium content by indirect access through portal

Description:	<p>Users of the service can purchase content credits in two ways. First, by establishing an account with the provider and purchasing credits using a credit card over the Internet or other medium. Second, by purchasing a pre-paid account for cash or other means in a form similar to pre-paid phone cards. The second method provides even greater anonymity to the user in that the provider, as well as the content provider, is unaware of the user's identity.</p> <p>The present invention thus allows anonymous observation of premium content. A purchaser (user) of premium content connects and logs in to the server system via the Internet or other electronic medium. The server presents the user with a number of options for viewing or otherwise observing premium content (i.e. HTML Document, Video or Audio Stream, etc.) from a variety of providers. Through these options the user submits a request for an item of content to the server. The server then retrieves the content from the content provider's system or from a local cached version. If the content contains links (i.e. HTML Links) to other items of content at the provider, the server changes these links into links that request the same content from the server. The content is then delivered to the user's observation device (i.e. Web Browser, Telephone, etc.). For content that is live or provided interactively by the content provider, the server establishes an anonymously routed connection to the content provider. If the item fee is based on the amount of time the user spends observing the content, then the server begins a timer. When the user concludes the observation of the content the user's account is debited for the amount of the fee. The provider's account is credited for the content viewed. The user makes all payments to the provider. The provider makes all payments to the providers. There are no direct payments made from the user to the content provider and no records are maintained of the user's content selection, therefore ensuring anonymity. In addition, the user's records (i.e. Web Browser History Files, Phone Records, etc.) will only reveal a connection to the provider and not the content provider.</p> <p>BRIEFDESCRIPTION OF THE DRAWINGS</p> <p>The Description of the Invention and Preferred Implementation makes reference to the schematics and models. These include the following:</p> <p>FIG. 1--Component Diagram</p> <p>This UML Package Diagram shows an overview of the logical design of the complete System in the preferred three-tier, component-based architecture.</p> <p>FIG. 2--Deployment Diagram</p> <p>This UML Deployment Diagram shows one of the possible physical deployment methods for a complete System.</p> <p>FIG. 3--Application Server Component Class Diagram</p> <p>This UML Class Diagram shows the association between classes in the Application Server Component.</p> <p>FIG. 4--Database Model</p> <p>This Entity Relationship Diagram shows the database table and relationship structures for the Database.</p> <p>FIG. 5--Method--Use Case Diagram</p> <p>This UML Use Case Diagram shows the primary user interactions with the System.</p> <p>FIG. 6--Method--Activity Diagram</p> <p>This UML Activity Diagram shows the Method for retrieving and/or connecting anonymous Users to premium Content from Providers</p>
---------------------	--

Attachment F *con't*

United States Patent 7,111,078

System and method for anonymous observation and use of premium content by indirect access through portal

<p>Description:</p>	<p>FIG. 7--Method--Collaboration Diagram</p> <p>This UML Collaboration Diagram shows the interaction of Application Server objects used to enact the Method for retrieving and/or connecting anonymous Users to premium Content from Providers.</p> <p>FIG. 8--Method--Sequence Diagram</p> <p>This UML Sequence Diagram shows the interaction of Application Server objects used to enact the Method for retrieving and/or connecting anonymous Users to premium Content from Providers, and other related processes.</p> <p>DETAILED DESCRIPTION OF THE INVENTION</p> <p>The preferred implementation of the system is herein set forth in detail with reference to diagrams and schematics. The descriptions reference the diagrams using reference numbers as identified in the diagrams and schematics. Reference numbers in this section are surrounded by square brackets [].</p> <p>Logical Component Design and Architecture</p> <p>The preferred implementation of the system is that of three-tier, component-based architecture as outlined in FIG. 1--Component Diagram. The system is organized into three distinct logical layers: the User Layer [110], the Application Layer [120], and the Data Layer [130].</p> <p>Components in the User Layer [110], in response to actions by the User, submits requests to components in the Application Layer [120], which in turn processes the requests and returns the requested information to the User Layer [110]. In processing requests from the User Layer [110], components in the Application Layer [120] may submit requests to components in the Data Layer [130], which in turn processes the request and returns the requested information to the Application Layer [120]. In addition to submitting requests to the Data Layer [130], the Application Layer [120] may submit requests to Provider Content Servers [134] for Content. Content returned by these servers to the Application Layer [120] would then be passed on to the User Layer [110].</p> <p>Components within a given layer will also collaborate to achieve that layer's objective.</p> <p>The User Layer</p> <p>The User Layer [110] embodies the user interface and presentation logic of the system. It consists of the following components: User Operating Platform [111], Content Viewing Components [112], and the User Interface Component [113].</p> <p>The User Operating Platform [111] is independent of the system and may include a variety of commercially available operating platforms (i.e. Windows 95/98/NT/2000, Macintosh, UNIX, Linux, set-top boxes, telephones, etc.). Its purpose is to provide the User with the ability to with access to the Internet or other network, and to provide the facilities to run the Content Viewing Components [112].</p> <p>The Content Viewing Components [112] are also independent of the system and may include a variety of commercially available content viewing utilities (i.e. Microsoft Internet Explorer, Netscape Communicator, Adobe Acrobat, Real Player, etc.). Their purpose is to provide the User with ability to access the Portal and use available Content.</p> <p>The User Interface Component [113] is a component developed and maintained by the Portal. It is independent of, but dependent on the Application Server Component [122]. Its responsibility is to accept input from the User and return content and other output to the User's Content Viewing Components [112]. Its operations should provide User's with the following features: 1. The ability to submit User log-in requests. 2. The ability to select Content for viewing. 3. The ability to load Content into a Content Viewing Component [112]. 4. The ability to terminate the use of the Content.</p>
----------------------------	--

Attachment F *con't*

United States Patent 7,111,078

System and method for anonymous observation and use of premium content by indirect access through portal

<p>Description:</p>	<p>For each User, the User Interface Component [113] should request a unique Connection object (described in more detail later) from the Application Server [122]. The User Interface Component [113] requests services from the Connection object that include but are not limited to log-in requests and Content requests.</p> <p>Upon receiving results from these requests, it is the User Interface Component's [113] responsibility to present the results to the User and provide a way for the User to interact with the Content.</p> <p>The specific implementation of the User Layer [110] is based on the Content's format, the User Operating Platform [111], the Content Viewing Components [112], and the Content Server and Delivery Components [121].</p> <p>The Application Layer</p> <p>The Application Layer [120] embodies the business rules and application logic of the system. It consists of the following components: Content Server and Delivery Components [121] and the Application Server Component [122].</p> <p>The Content Server and Delivery Components [121] are also independent of the system and may include a variety of commercially available web service platforms and add-ins (i.e. Microsoft Internet Information Server, Active Server Pages, iPlanet Web Server, Cable Broadcast Systems, Telephone Systems, etc.).</p> <p>The Application Server Component [122] is a core component of the system and is described in greater detail later.</p> <p>The Data Layer</p> <p>The Data Layer [130] embodies the data storage and retrieval logic of the system. It consists of the following components: Data Access Component [131] and Relational Database Management System [132], the Database [133] and Content Provider Servers [134].</p> <p>The Data Access Component [131] is independent of the system and may be implemented using a variety of commercially available components and services (i.e. Microsoft DAO, Microsoft ADO, ODBC, JDBC, proprietary database API's, etc.). Its purpose is to provide programmers with an Application Programmer's Interface (API) for communicating with the Relational Database Management System [132] and manipulate data in the Database [133].</p> <p>The Relational Database Management System (RDBMS) [132] is also independent of the system and may be implemented using a variety of commercially available RDBMS servers (i.e. Oracle, MS-SQL Server, IBM DB/2, etc.). Its purpose is to provide a mechanism to store information in the Database [133].</p> <p>The Database [133] is a core component of the system and is described in greater detail below.</p> <p>The Content Provider Servers [134] are independent of the system. These servers are maintained by the Providers of premium Content and can include a variety of commercially available products (i.e. web servers, file servers, database server, broadcast systems, telephone systems, etc.).</p> <p>Physical Deployment Model</p> <p>The preferred physical deployment model for the System is that of distributed system. FIG. 2--Deployment Diagram outlines a typical implementation of that model.</p> <p>The system can be deployed on up to 4 or more nodes (computers or other physical devices): User Device [210], Web Server [220], Application Server [230], and Database Server [240]. These devices are then connected using currently available network technology.</p>
----------------------------	--

Attachment F *con't*

United States Patent 7,111,078

System and method for anonymous observation and use of premium content by indirect access through portal

Description:	<p>User Device Node</p> <p>The users of a Portal maintain the User Device Node [210]. Components installed on this machine include the User Operating System [211], and the Content Viewing Components [212]. User devices may include but are not limited, personnel computers, televisions and set-top boxes, or telephones.</p> <p>Content Server Node</p> <p>The Portal maintains the Content Server Node [220]. Components installed on this machine include the Content Service Components [221] and the User Interface Component [222]. Content Servers may include but are not limited to web servers, database servers, file servers, electronic libraries or electronic broadcasting system.</p> <p>Application Server Node</p> <p>The Application Server [230] is maintained by the Portal. Components installed on this machine include the Application Server Component [231] and the Data Access Component [232].</p> <p>Database Server Node</p> <p>The Portal maintains the Database Server [240]. Components installed on this machine include the Relational Database Management System [241] and the Database [242].</p> <p>Content Provider Server Nodes</p> <p>The various Content Providers maintain the Content Provider Server Nodes [250].</p> <p>These nodes may include a variety of server types and components including but not limited to web servers, file servers, database server, broadcast systems and telephone systems.</p> <p>Alternative Deployment Methods</p> <p>In addition to the deployment method outlined here and in FIG. 2, alternative deployment methods can be used. Alternative deployment methods may be selected based on factors such as the number of simultaneous users and the available technology for the given Content format.</p> <p>In one alternative method, all components installed on the Content [221, 222], Application [231, 232], and Data [241, 242] Servers Nodes, as outlined above, can be installed instead on a single server machine, eliminating the need for two of the three machines maintained by the Portal.</p> <p>In a second alternative, components installed on the Application Server Node [231, 232], as outlined above, can be installed instead with components on the Web Server Node [220], eliminating the need for a separate Application Server Node [230].</p> <p>In a third alternative, components installed on the Application Server Node [231, 232], as outlined above, can be installed instead with the components on the Database Server Node [241, 242], eliminating the need for a separate Application Server Node [230].</p> <p>In a fourth alternative, multiple instances of the Content [220] and Application [230] Server Nodes can be deployed to handle requests from large numbers of Users.</p> <p>The Application Server Component</p> <p>The preferred implementation is that of an object-oriented component as outlined in FIG. 3--Application Server Component Class Diagram.</p>
---------------------	--

Attachment F *con't*

United States Patent 7,111,078

System and method for anonymous observation and use of premium content by indirect access through portal

<p>Description:</p>	<p>Component Overview</p> <p>The Application Server Component embodies the business rules and application logic of the System. This component has the following objectives: 1. Maintain the state of the data associated with systems entities. 2. Interact with Database for object and data persistence. 3. Maintain and enforce data integrity and security. 4. Maintain an accounting of User and Provider credit balances. 5. Retrieve, process and maintain cached versions of Provider Content. 6. Process Provider Content as follows: Convert links to additional Content into Content requests to the Application Server Component. This serves the purpose of keeping the User inside of the Portal, preventing them from viewing content directly from the Provider's Server, therefore maintaining anonymity.</p> <p>To accomplish these objectives the preferred implementation organizes the component into the following class modules: Connection [310], User [320], User Credit [330], User Debit [340], Provider [350], Provider Content [360], and Provider Credit [370].</p> <p>This component can be implemented using a variety of currently available object-oriented programming languages and technologies (i.e. C++, Visual Basic, COM, DCOM, Java, JavaBeans, CORBA, etc.).</p> <p>The Connection Class</p> <p>The Connection Class [310] represents the root class of the Application Server Component. It provides the following operations: 1. Maintains the state Connection objects. 2. Creates, retrieves and maintains User [320], User Credit [330], User Debit [340], Provider [350], and Provider Credit [370] objects. 3. Retrieve Content from Content Service Provider Nodes [250] 4. Verifies User log in requests. 5. Maintains a connection to the Database [133] using the Data Access Component.</p> <p>The User Interface Component [114] will establish a reference to this object when Users connect to the Portal.</p> <p>The User Class</p> <p>The User Class [320] represents a User Account of the System. An Instance (or object) of this class exists for each user that is logged in to the system. It provides the following functionality: 1. Maintains the state of User objects. 2. Maintains User object persistence in the User Table [520] using the Data Access Component. 3. Creates, retrieves and maintains User Credit [330] and User Debit [340] objects. 4. Maintains accounting of the User's Credits and Charges. 5. Verifies User passwords.</p> <p>The User Credit Class</p> <p>The User Credit Class [330] represents a User's purchase of Credits. It is used by user interface components, provided by the portal, that allow the User to purchase Content rights. It provides the following functionality: 1. Maintains the state of User Credit objects. 2. Maintains User Credit object persistence in the User Credit Table [530] using the Data Access Component.</p> <p>In addition, this class can maintain information on the specific Provider or Provider Content for which the credit can be used.</p> <p>The User Debit Class</p> <p>The User Debit Class [340] represents a charge for a User viewing Pay-per-view Content. Instances of this class exist when posting debits to the User's account. It provides the following functionality: 1. Maintains the state of User Debit objects. 2. Maintains User Debit object persistence in the User Debit Table [540].</p> <p>In addition, this class can maintain information on the specific Provider or Provider Content for which the User account was charged.</p>
----------------------------	--

Attachment F *con't*

United States Patent 7,111,078

System and method for anonymous observation and use of premium content by indirect access through portal

Description:	<p>The Provider Class</p> <p>The Provider Class [350] represents a Content Provider. Instances of this class exist when a User is using the Content from the Provider. It provides the following functionality: 1. Maintains the state of Provider objects. 2. Maintains Provider object persistence in the Provider Table [550] using the Data Access Component [131, 232]. 3. Creates, retrieves and maintains Provider Content [360] and Provider Credit [370] objects. 4. Maintains accounting of the Providers Credits and Content Usage. 5. Retrieves, processes and returns the Content information. 6. Optionally maintains a cached version of the Content close to the Portal's Application Server.</p> <p>The Provider Content Class</p> <p>The Provider Content Class [360] represents a specific item of Pay-per-view Content. Instances of this class exist when a User is using the Content it represents. It provides the following functionality: 1. Maintains the state of Provider Content objects. 2. Maintains Provider Content object persistence in the Provider Content Table [560] using the Data Access Components. 3. Creates, retrieves and maintains Provider Credit [370] objects. 4. Retrieves, processes and returns the Content from Provider. 5. Optionally maintains a cached version of the Content closer to the Portal's Application Server</p> <p>The Provider Credit Class</p> <p>The Provider Credit Class [370] represents a credit for Provider Content that is being viewed. Instances of this class exist when posting a credit to the Provider's account. It provides the following functionality: 1. Maintains the state of Provider Credit objects. 2. Maintains Provider Credit object persistence in the Provider Credit Table [570] using the Data Access Components. 3. Maintains accounting of fees earned during the session.</p> <p>The Database</p> <p>The preferred implementation is that of a relational database as outlined in FIG. 4--Database Model.</p> <p>Database Overview</p> <p>The Database defines the structure for information stored and maintained by the System. This database has the following objectives: 1. Persistently maintain the state of the objects and other data of the system. 2. Provide procedures forsaking, retrieving and deleting data.</p> <p>To accomplish these objectives the preferred implementation organizes the database into the following table definitions: User [420], User Credit Purchase [430], User Session [440], Provider [450], Provider Content [460], and Provider Credit [470].</p> <p>The User Table</p> <p>The User Table [420] is used to persist the state of User objects. It provides data fields for storing the User Id (a primary key that uniquely identifies each User), log in, User's credit balance, and other information.</p> <p>The User Credit Table</p> <p>The User Credit Table [430] is used to persist the state of User Credit objects. It provides data fields for storing the User Id (a foreign key identifying the User credited), and the date and amount credited.</p> <p>The User Debit Table</p> <p>The User Debit Table [440] is used to persist the state of User Debit objects. It provides data fields for storing the User Id (a foreign key identifying the User), the time the User entered and exited the Content, and the amount of debited to their account.</p>
---------------------	---

Attachment F *con't*

United States Patent 7,111,078

System and method for anonymous observation and use of premium content by indirect access through portal

Description:	<p>The Provider Table</p> <p>The Provider Table [450] is used to persist the state of Provider objects. It provides data fields for storing the Provider Id (a primary key that uniquely identifies each Provider), name, address information, content location, and Content pricing information.</p> <p>The Provider Content Table</p> <p>The Provider Content Table [460] is used to persist the state of Provider Content objects. It provides data fields for the Provider Content Id (a primary key that uniquely identifies each item of Provider Content), the Provider Id (a foreign key identifying the Provider), content location and pricing information. This table may also provide data elements for storing cached or local copies of the Content.</p> <p>The Provider Credit Table</p> <p>The Provider Credit Table [470] is used to persist the state of Provider Credit object. It provides data fields for the Provider Id (a foreign key identifying the Provider), the Provider Content Id (a foreign key identifying a specific item of Provider Content (optional)), the time the Content was entered and exited, content location, and the amount of credited to the Provider account.</p> <p>The Method</p> <p>The process and preferred implementation of the Method is outlined in FIG. 5--Method--Use Case Diagram, FIG. 6--Activity Diagram, FIG. 7--Collaboration Diagram, and FIG. 8--Sequence Diagram.</p> <p>The Process</p> <p>The Process is the sequence of events used for delivering Pay-per-view Content to Anonymous Users. FIG. 5, a UML Activity Diagram, shows an overview of this process. The numbered items in the diagram represent the activities that take place during the process. Descriptions of these activities follow. 601. The User, via the User Device submits a request to the portal for an item or area of Content. 602. The System retrieves information about the content from the Database. 603. If the Content is of the type that can be delivered, the System will retrieve the actual Content from either the Content Provider Servers or from a local copy of cached version of the Content. This may be stored in the Database or other local storage system. 604. The Content is examined for the presence of direct links or requests to the Content Provider. 605. If the Content does contain such links, the links are reformatted or replaced by request links to the System. This will prevent the User from directly linking to the Content Provider, which nullify their anonymity. 606. The Content is delivered to the User Device via currently available technologies (i.e. web servers, database servers, telephone systems, cable systems, etc.). 607. Referring to Activity 602, If the Content is of the type that can not be delivered to the User anonymously and a connection to the Content Provider Nodes, then the system will establish a link to said Node acting as a proxy for the User. 608. The system will establish a link to the User Device acting as a proxy for the Server.</p> <p>Content from the Provider will then be routed via these connections. The specific connections and routing technologies to be used are independent of the system and can be implemented using a variety of commercially available products. 609. When the User Interface Component notifies the System that User has completed observing the Content, any anonymously routed connections established between the User and Content Provider are Terminated. 610. A Credit for the observation of the Content is posted to the Provider's account. 611. A Debit for the observation of the Content is posted to the User's account.</p> <p>User Interactions</p> <p>For the viewing Pay-per-view Content anonymously, the User will have two primary interactions with the system: requesting Content from the Portal and completing the viewing of that content. FIG. 6, a UML Use Case Diagram shows the various interactions between the User and the System process.</p>
---------------------	---

Attachment F *con't*

United States Patent 7,111,078

System and method for anonymous observation and use of premium content by indirect access through portal

Description:	<p>The User may request content [510] through a wide variety of currently available technologies. These include but are not limited to the following: 1. Selecting content or provider link from the web site of the Portal. 2. Entering a content or provider identifier via a computer based data entry system. 3. Entering a content or provider identified via a prompt driven phone system. 4. Selecting a channel or other option via a set-top box or television.</p> <p>The User Content request [510] will be honored by the system, either by retrieving [511] and possibly reformatting [512] the Content or by establishing an anonymously routed connection between the User Device and the Content Server [513].</p> <p>The User may complete the observation of content [520] in a wide variety of ways that depend primarily on the implementation technology. These methods of completing the observation include but are not limited to the following: 1. Selecting a link to a different provider, or a different item or area of content via the user interface provided. 2. Selecting an option to logout of the system. 3. Closing or exiting the web browser or other viewing component. 4. Disconnecting or turning off the User Device. 5. Changing the channel on of turning of a set-top box or television. 6. Hanging up the phone.</p> <p>When the User has notified the Portal, through one of the above or other means, that the Content observation is complete [520], the System will system will account for the session by posting a credit to the Provider's account [521] and a debit to the User's account [522]. To preserve User anonymity, no connection or links between these posting are maintained.</p> <p>Component Object Interactions</p> <p>The preferred implementation of the Method is an object-oriented software component as described earlier (Application Server Component). To achieve the objectives of the Method, objects (or class instances) in the Application Server Component collaborate with each other, each performing a particular task. Each object sends messages to others by calling the methods (or functions) that are provided by the other objects. FIG. 7, a UML Collaboration Diagram, shows the inter-object message scheme for the Application Server Component. Ordered descriptions of these messages follow: 701. An object from the User Interface Component [7000] sends a Log-In request to the Connection object [7100]. 702. The Connection object [7100] sends a Log-in message to the User object [7200]. 703. An object from the User Interface Component [7000] sends a Content request to the Connection object [7100]. 704. The Connection object [7100] sends a Retrieve Content Information message to the Provider object [7500]. 705. The Provider object [7500] sends a Retrieve Information message to the Provider Content object [7600]. 706. (a) If the Content can be delivered, the Connection object [7100] sends a Retrieve Content message to the Provider Content object [7600]. (b) If the Content requires a all connection, the Content object [7100] sends a Provide Connection message to the Provider Content object [7600]. 707. If the Content contains direct links or requests to the Provider, the Provider Content [7600] sends a Reformat message to itself. 708. An object from the User Interface Component [7000] sends an Observation Complete message to the Connection object [7100]. 709. The Connection object [7100] sends a Terminate Connection message to the Provider Content object [7600]. 710. The Connection object [7100] sends a Post message to the Provider Credit object [7700]. 711. The Connection object [7100] sends a Post message to the User Debit object [7400].</p> <p>In addition to sending messages to other objects, some objects are responsible for the creation and deletion of objects. The Connection object is created by the User Interface Component a User connects to the System, and continues to exist until the user disconnects. Many other objects in the Application Server only need to exist for short periods of time. FIG. 8, a UML Sequence Diagram, shows the lifetime of such objects as various messages are processed by the Connection object [810].</p> <p>Upon receiving a log-in request [801] from the User Interface Component, the Connection object [810] creates a new instance [801.1] of a User object [820]. The Connection object [810] then sends the Login message [801.2] to the User object [820]. The User object continues to exist until the User disconnects and the Connection object is deleted.</p>
---------------------	---

Attachment F *con't*

United States Patent 7,111,078

System and method for anonymous observation and use of premium content by indirect access through portal

Description:	<p>Upon receiving a content request [802] from the User Interface Component, the Connection object [810] creates a new instance [802.1] of a Provider Object [850]. The Connection object [810] then sends a Retrieve Content Request message [802.2] to the Provider object [850]. In response to this message, the Provider object [850] creates a new instance [802.3] of a Provider Content object [860] and sends it the Retrieve Information message [802.4]. Both the Provider object [850] and the Provider Content object [860] continue to exist until the User disconnects. After the Connection object [810] examines the Content information, it either sends the Retrieve Content or the Provide Connection message [802.5] to the Provider Content object [860]. In response to the Retrieve Content message, the Provider Content retrieves the Content and if necessary sends a Reformat message [802.6] to itself.</p> <p>Upon receiving an observation complete message [803] from the User Interface Component, the Connection object [810], if a connection to the Content was provided, sends the Terminate Connection message [803.1] to the Provider Content object [860]. It then creates anew instance [803.2] of a Provider Credit [870], sends that object the Post message [803.3], and then deletes [803.4] the Provider Credit object [870]. It then creates a new instance [803.5] of a User Debit [840], sends that object the Post message [803.6], and then deletes [803.7] the User Debit object [840]. The Connection object [810] then deletes [803.8] the Provider object [850]. This deletion cascades a deletion [803.9] to the Provider Content object [860].</p> <p>Upon receiving a user disconnect message [804] from the User Interface Component, the Connection object [810] deletes [804.1] the User object [820]. NOTE--If the user is observing content when the user disconnect message [804] is received, the Connection object [810] will send an Observation Complete message [803] to itself.</p> <p>Resources Required for Implementation</p> <p>Content Delivery and Viewing Platforms</p> <p>As the design set forth herein is independent of any specific computing or other content delivery and viewing platform, the design can be applied to a wide variety of such platforms. Two distinct platforms are required: a content server and delivery platform and a user platform.</p> <p>The types of content server and delivery platforms the design herein could be applied to include but are not limited to the following: 1. Windows based computers (i.e. Pentium computers running Windows operating system, web server, and data server software). 2. UNIX based computers (i.e. Sparc workstation running UNIX operating system, web server, and data server software). 3. Other server capable computers (i.e. Linux systems, Mainframes computers, etc.). 4. Broadcast, cable and satellite based television and radio systems. 5. Telephone systems. 6. Voice response, recognition and generation systems.</p> <p>The types of user platforms the design herein could be applied to include but are not limited to the following: 1. Personal Computer systems (i.e. Windows, Macintosh, UNIX, Linux, etc.). 2. Internet access software (i.e. Microsoft Internet Explorer, Netscape Navigator, etc.). 3. Internet access devices (i.e. Internet terminals, television set-top boxes, etc.). 4. Computer based game systems. 5. Cable and satellite television and radio receivers. 6. Hand held and wearable computer devices. 7. Telephones</p> <p>Development Tools</p> <p>As the design set forth herein is independent of the specific implementation techniques, a wide variety of commercially available tools could be used to develop the components described. The types of tools that may be required include but are not limited to: 1. Object Oriented Programming tools (i.e. Visual C++, Visual Basic, Visual Age for Java, etc.) 2. Distributed Component Deployment tools (i.e. DCOM, CORBA, etc.) 3. Relational Database System (i.e. Oracle, MS SQL Server, IBM DB/2, etc.) 4. Web Component Development tools (i.e. Java, CGI, Perl, Visual Basic, Active Server Pages, etc.) 5. Browser and Other Component markup and scripting tools (i.e. JavaScript, VBScript, HTML, DHTML, etc.). 6. Broadcast, cable and satellite systems. 7. Telephone systems.</p>
---------------------	--

Attachment F *con't*

United States Patent 7,111,078

System and method for anonymous observation and use of premium content by indirect access through portal

Description:	<p>Programming and Other Talent</p> <p>The programming talent required to build the preferred implementation is dependent primarily on the target operating platform of the system. Typical skill set may include the following: 1. Object-oriented programming language skills. 2. Component-based and multi-tier, client-server development skills. 3. Relation database programming skills. 4. Thin-client and web programming skills. 5. HTML and other presentation design skills. 6. Web Server and Database Server implementation and administration skills. 7. Broadcast, Cable and Satellite system programming skills. 8. Telephone system programming skills.</p> <p>The design set forth herein is sufficient as to not require a programmer to create any new invention to implement the system. The techniques required to implement the various designs of the method and system are based on currently available and commonly known technologies, programming techniques and algorithms.</p> <p>While a preferred embodiment and various alternatives have been set forth above, those skilled in the art will readily appreciate that other embodiments are possible within the scope of the invention. For example, communication networks other than the Internet, such as the public switched telephone network and proprietary data networks, can be used. Also, any hardware capable of use with such networks can be used. Furthermore, while the portal has been disclosed as usable with multiple providers, it can be used with only one provider. Moreover, different networks could be used to connect the system to the user and to the providers; for example, the user could dial up to the system, which would then function as an ISP in connecting the user to the providers. Therefore, the present invention should be construed as limited only by the appended claims.</p> <p style="text-align: center;">* * * * *</p>
---------------------	---

Attachment G

United States Patent 7,111,078

Figure 1 MA`AT/Gara Component Diagram

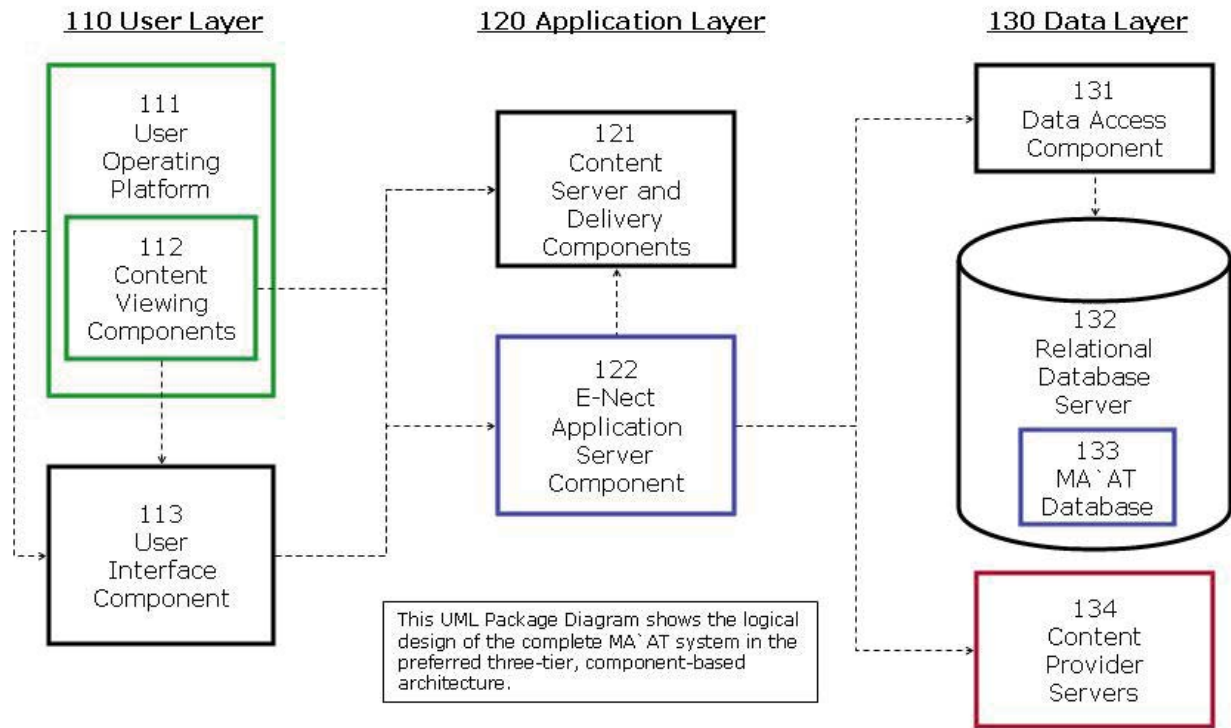

Attachment G *con't*

United States Patent 7,111,078

Figure 2 MA`AT Deployment Diagram

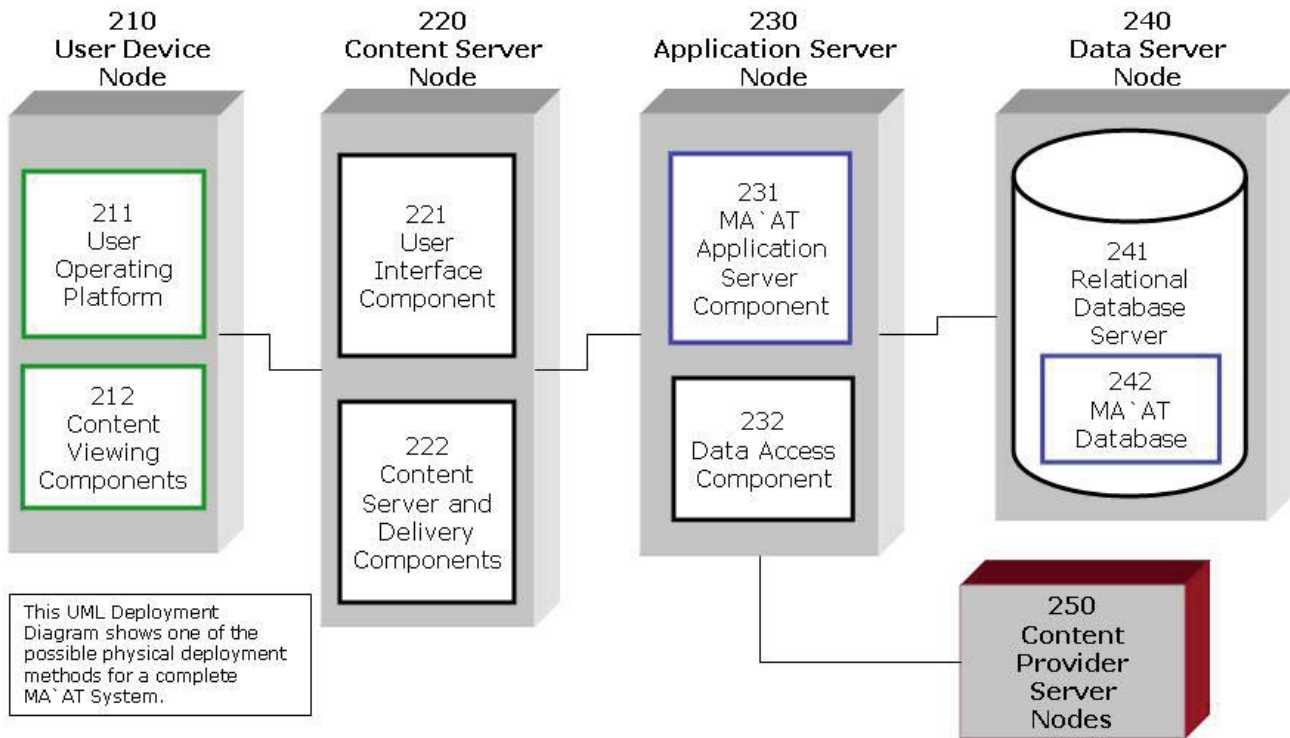

Attachment G *con't*

United States Patent 7,111,078

Figure 3
MA`AT Application Server Component Class Diagram

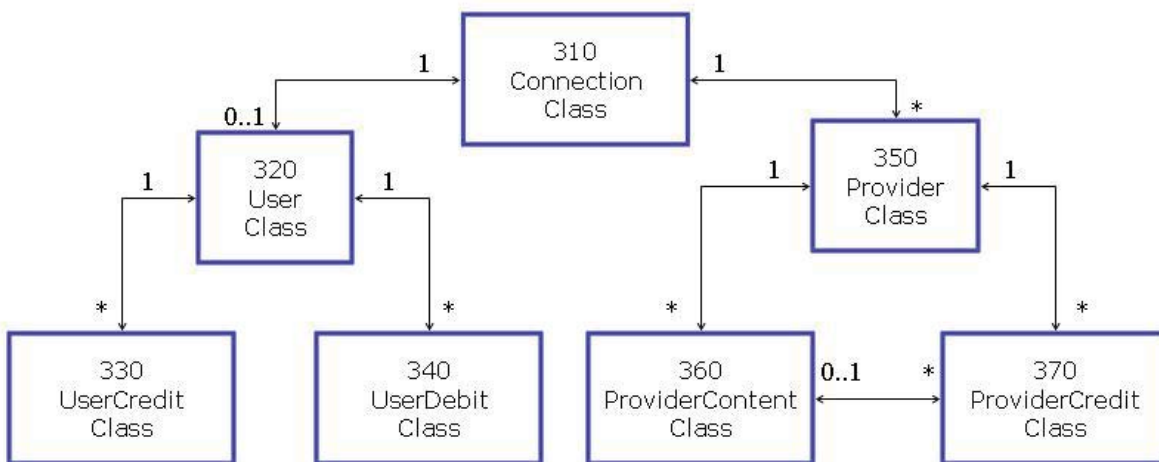

This UML Class Diagram shows the associations between classes of the MA`AT Application Server Component.

Attachment G *con't*

United States Patent 7,111,078

Figure 4
MA`AT Database Model

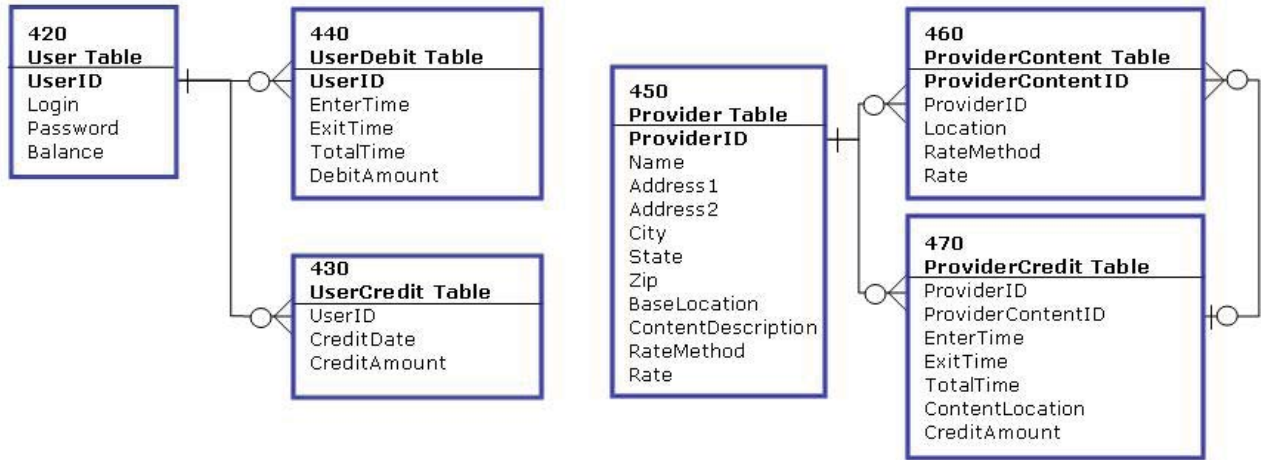

This Entity Relationship Diagram shows database table and relationship structures for the MA`AT Database.

Attachment G *con't*

United States Patent 7,111,078

Figure 5 MA`AT Method - Use Case Diagram

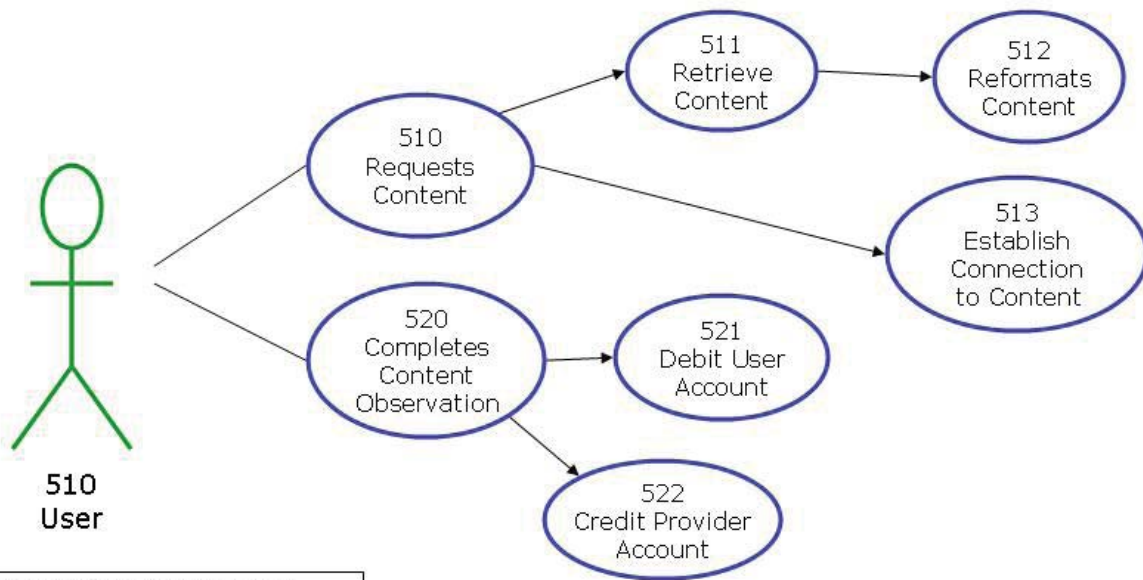

This UML Use Case Diagram shows the primary user interactions with the MA`AT System.

Attachment G *con't*

United States Patent 7,111,078

Figure 6
MA`AT Method - Activity Diagram

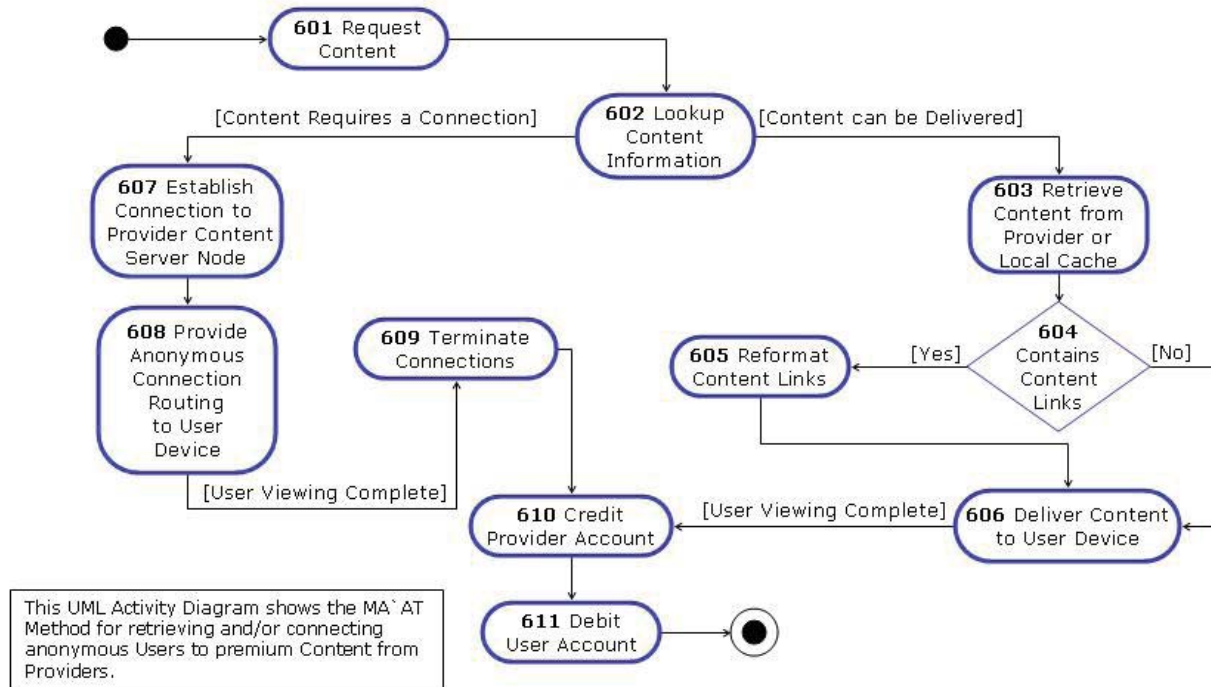

Attachment G *con't*

United States Patent 7,111,078

Figure 7
MA`AT Method - Collaboration Diagram

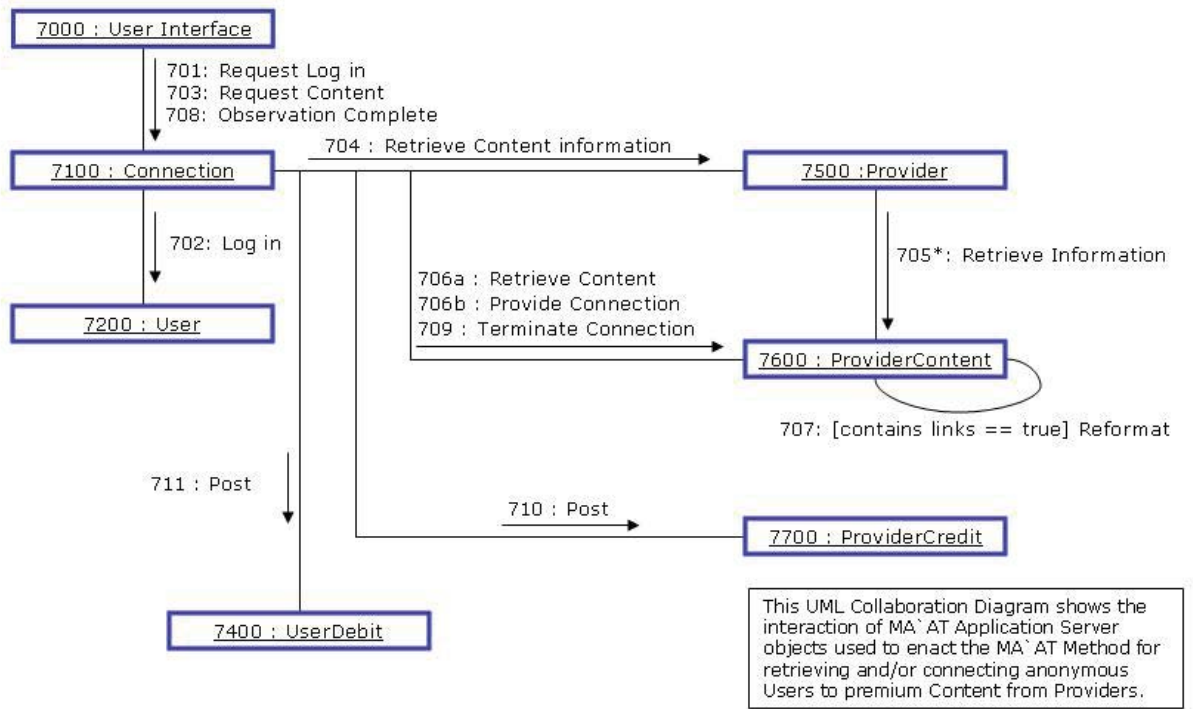

Attachment G *con't*

United States Patent 7,111,078

Figure 8
MA`AT Method - Sequence Diagram

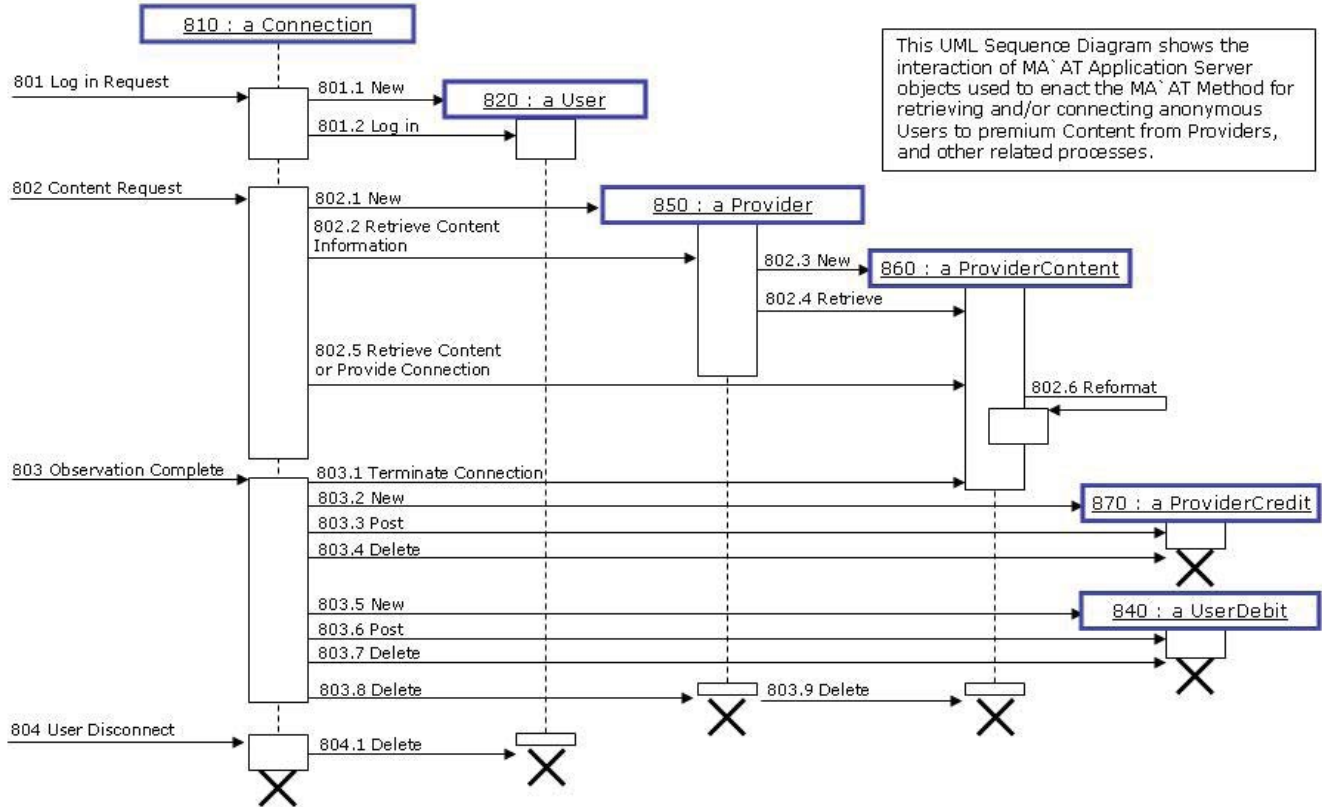

Attachment H - Assignment Change



MCGT/DSE

UNITED STATES PATENT AND TRADEMARK OFFICE

UNDER SECRETARY OF COMMERCE FOR INTELLECTUAL PROPERTY AND
DIRECTOR OF THE UNITED STATES PATENT AND TRADEMARK OFFICE

FEBRUARY 16, 2007

BLANK ROME LLP
600 NEW HAMPSHIRE AVENUE, N.W.
WASHINGTON, D.C. 20037

PTAS

BLANK ROME LLP

FEB 22 2007

RECEIVED
COUNSELORS AT LAW



103371695A

UNITED STATES PATENT AND TRADEMARK OFFICE NOTICE OF RECORDATION OF ASSIGNMENT DOCUMENT

THE ENCLOSED DOCUMENT HAS BEEN RECORDED BY THE ASSIGNMENT DIVISION OF THE U.S. PATENT AND TRADEMARK OFFICE. A COMPLETE MICROFILM COPY IS AVAILABLE AT THE ASSIGNMENT SEARCH ROOM ON THE REEL AND FRAME NUMBER REFERENCED BELOW.

PLEASE REVIEW ALL INFORMATION CONTAINED ON THIS NOTICE. THE INFORMATION CONTAINED ON THIS RECORDATION NOTICE REFLECTS THE DATA PRESENT IN THE PATENT AND TRADEMARK ASSIGNMENT SYSTEM. IF YOU SHOULD FIND ANY ERRORS OR HAVE QUESTIONS CONCERNING THIS NOTICE, YOU MAY CONTACT THE EMPLOYEE WHOSE NAME APPEARS ON THIS NOTICE AT 571-272-3350. PLEASE SEND REQUEST FOR CORRECTION TO: U.S. PATENT AND TRADEMARK OFFICE, MAIL STOP: ASSIGNMENT SERVICES BRANCH, P.O. BOX 1450, ALEXANDRIA, VA 22313.

RECORDATION DATE: 02/06/2007

REEL/FRAME: 018891/0954
NUMBER OF PAGES: 8

BRIEF: ASSIGNMENT OF ASSIGNOR'S INTEREST (SEE DOCUMENT FOR DETAILS).

ASSIGNOR:
HIRST, STEVEN B.

DOC DATE: 01/31/2007

ASSIGNOR:
WALDRON, MELODIE

DOC DATE: 01/15/2007

ASSIGNOR:
KEORKUNIAN, GARY S.

DOC DATE: 12/19/2006

ASSIGNEE:
MA'AT, INC.
2406 NEW MARKET SQUARE SOUTH
BENSALEM, PENNSYLVANIA 19020

ASSIGNEE:
GARA SYSTEMS, INC.
721 DRESHER ROAD, SUITE 2400
HORSHAM, PENNSYLVANIA 19044

DOCKETED
109246-0103
FEB 22 2007
Sm...

Action Due _____
Due Date _____